

Equity 1317

Computer workstation with hand crank adjustment

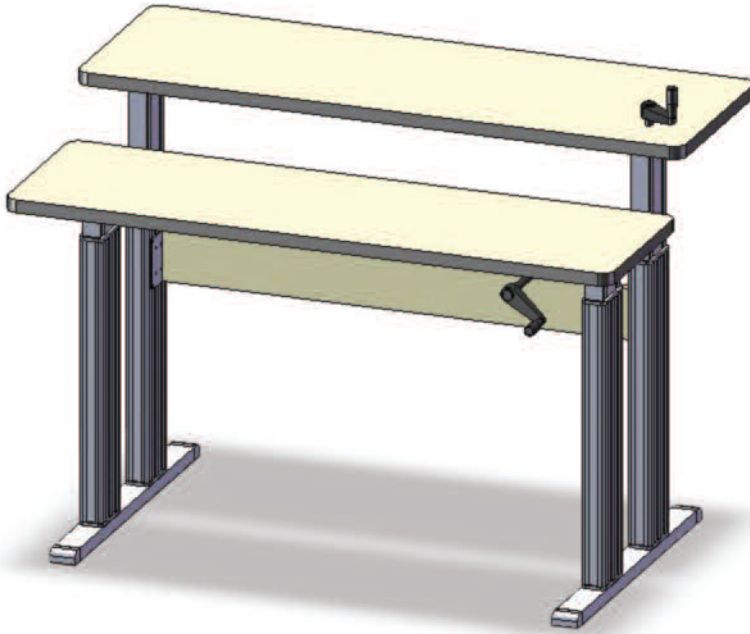

Features

- An ergonomic solution providing variable sit-to-stand height range for individual positioning or multi-user environments
- Adjustment Range of 24-38 inches for a 14 inch travel range
- Front and Rear worksurfaces adjust independently for optimal ergonomics
- Easy to turn hand crank adjusts at 8 cranks per inch
- Front crank is positioned under the table and retracts out of the way
- Rear worksurface adjusts with a top crank
- Meets or exceeds ANSI/BIFMA standard, BSR/HFES 100 Standard, and ANSI A117.1 (wheelchair accessibility) Standard
- Lift capacity of 200 lbs for each surface
- Ships Ready to Assemble and assembles easily

Technical Data

- 16 Gauge steel feet coated in graphite gray powdercoated finish
- Anodized aluminum telescoping legs
- Durable laminate workstation tops 1½ inch thick
- Edge treatment is 2mm vinyl
- Custom workstation top sizes and finishes available.

